



Tarauds Coupants en acier fritté PM  
Convient pour les aciers inoxydables, Super Duplex

# M-SFT-DUPLEX

Volume 5.1



50 nouvelles dimensions disponibles:  
Métrique & métrique fin,  
aussi avec trou d'huile.

## KEY FEATURES: M-SFT-DUPLEX

---



**1** Rigidité améliorée  
diamètre d'âme optimisé  
plus de dents q'un taraud classique

**2** Évacuation des copeaux améliorée  
Angle d'hélice optimisé, aussi avec  
trou d'huile

**3** Résistance au collage améliorée  
Revêtement TIN idéal pour les  
Super Duplex grâce à sa  
résistance à la chaleur

# M-SFT-DUPLEX NOUVELLE DIMENSION

Taraudage | Taraud coupant | Metrique

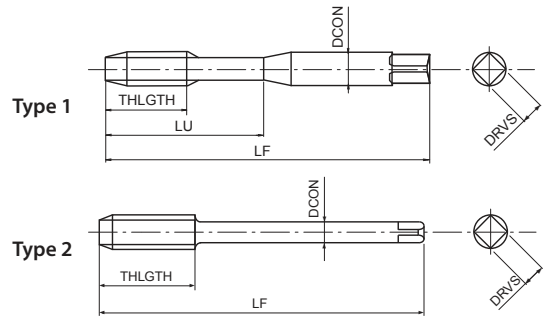

- Taraud coupant hélicoïdal fritté pour trous borgnes
- Revêtement TiN pour une meilleure résistance à la chaleur
- Pour les matériaux difficiles tels que 304L, 316L, 15-5PH & 17-4PH, Super Duplex 1.4410, Inconel 625

<b>P</b> C < 0,2%	<b>P</b> 0,25 < C < 0,4	<b>P</b> C ≥ 0,45%	<b>P</b> SCM	<b>M</b> INOX	<b>S</b> Inconel 625	<b>S</b> Ti Gr.2		
				3-15 Super Duplex	2-3 15-5 PH	3-6 17-4 PH	m/min	
<b>M</b>	<b>PM</b>	<b>TiN</b>	<b>50°</b>	<b>ISO 2 6HX</b>	<b>C/2,5</b>		<b>DIN 371</b>	<b>DIN 376</b>

EDP	TD	TP	LF	THLGTH	LU	DCON	DRVS	NOF	Type	DIN	Prix
48336125	2	0,4	45	3,2	10	2,8	2,1	2	1	371	
48336133	<b>NEW</b> 2,5	0,45	50	3,6	13	2,8	2,1	2	1	371	
48336138	3	0,5	56	4	18	3,5	2,7	3	1	371	
48336144	4	0,7	63	5,6	21	4,5	3,4	3	1	371	
48336149	5	0,8	70	6,4	25	6	4,9	3	1	371	
48336155	6	1	80	8	30	6	4,9	3	1	371	
48336161	8	1,25	90	10	35	8	6,2	3	1	371	
48336169	10	1,5	100	12	39	10	8	4	1	371	
48336179	12	1,75	110	14	-	9	7	4	2	376	
48336191	14	2	110	16	-	11	9	4	2	376	
48336202	16	2	110	16	-	12	9	4	2	376	
48336214	18	2,5	125	25	-	14	11	4	2	376	
48336228	20	2,5	140	25	-	16	12	4	2	376	
48336238	22	2,5	140	25	-	18	14,5	4	2	376	
48336247	24	3	160	30	-	18	14,5	4	2	376	

Taraudage | Taraud coupant  
Metrique



# M-OIL-SFT-DUPLEX NOUVEAU

Taraudage | Taraud coupant | Metrique

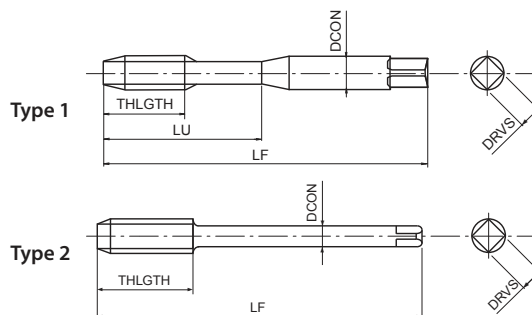

- Taraud coupant hélicoïdal fritté pour trous borgnes
- Revêtement TiN pour une meilleure résistance à la chaleur
- Pour les matériaux difficiles tels que 304L, 316L, 15-5PH & 17-4PH, Super Duplex 1.4410, Inconel 625
- Trou d'huile central

Taraudage | Taraud coupant

<b>P</b> ○ C < 0,2%	<b>P</b> ○ 0,25 < C < 0,4	<b>P</b> ○ C ≥ 0,45%	<b>P</b> ○ SCM	<b>M</b> ● INOX	<b>S</b> ● Inconel 625	<b>S</b> ● Ti Gr.2	
				<b>3-15</b> Super Duplex	<b>2-3</b> 15-5 PH	<b>3-6</b> 17-4 PH	<b>m/min</b>
<b>M</b>	<b>PM</b>	<b>TiN</b>	<b>50°</b>	<b>ISO 2 6HX</b>	<b>C/2,5</b>	<b>DIN 371</b>	<b>DIN 376</b>

EDP	TD	TP	LF	THLGTH	LU	DCON	DRVS	NOF	Type	DIN	Prix
48380155	6	1	80	8	30	6	4,9	3	1	371	
48380161	8	1,25	90	10	35	8	6,2	3	1	371	
48380169	10	1,5	100	12	39	10	8	4	1	371	
48380179	12	1,75	110	14	-	9	7	4	2	376	
48380191	14	2	110	16	-	11	9	4	2	376	
48380202	16	2	110	16	-	12	9	4	2	376	
48380214	18	2,5	125	20	-	14	11	4	2	376	
48380228	20	2,5	140	20	-	16	12	4	2	376	
48380238	22	2,5	140	20	-	18	14,5	4	2	376	
48380247	24	3	160	24	-	18	14,5	4	2	376	



Metrique

# M-LT-SFT-DUPLEX NOUVEAU

Taroudage | Taraud coupant | Metrique

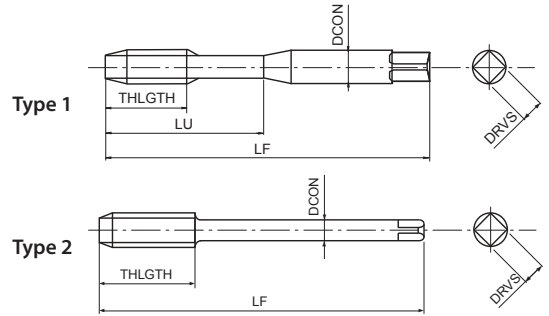

- Taraud coupant hélicoïdal fritté pour trous borgnes
- Revêtement TiN pour une meilleure résistance à la chaleur
- Pour les matériaux difficiles tels que 304L, 316L, 15-5PH & 17-4PH, Super Duplex 1.4410, Inconel 625
- Pour le taroudage profond d'accès & 3xD longueur de goujure

<b>P</b> ○ C < 0,2%	<b>P</b> ○ 0,25 < C < 0,4	<b>P</b> ○ C ≥ 0,45%	<b>P</b> ○ SCM	<b>M</b> ● INOX	<b>S</b> ● Inconel 625	<b>S</b> ● Ti Gr.2	
				3-15 Super Duplex	2-3 15-5 PH	3-6 17-4 PH	m/min
<b>M</b>	<b>PM</b>	<b>TiN</b>	<b>50°</b>	<b>ISO 2 6HX</b>	<b>C/2,5</b>		

EDP	TD	TP	LF	THLGTH	LU	DCON	DRVS	NOF	Type	Prix
48381125	2	0,4	80	3,2	12	2,8	2,1	2	1	
48381133	2,5	0,45	100	3,6	15,5	2,8	2,1	2	1	
48381138	3	0,5	100	4	21	3,5	2,7	3	1	
48381144	4	0,7	125	5,6	25	4,5	3,4	3	1	
48381149	5	0,8	160	6,4	30	6	4,9	3	1	
48381155	6	1	160	8	36	6	4,9	3	1	
48381187	6	1	160	8	-	4,5	3,4	3	2	
48381161	8	1,25	180	10	43	8	6,2	3	1	
48381188	8	1,25	180	10	-	6	4,9	3	2	
48381169	10	1,5	200	12	49	10	8	4	1	
48381189	10	1,5	200	12	-	7	5,5	4	2	
48381179	12	1,75	200	14	-	9	7	4	2	
48381191	14	2	200	16	-	11	9	4	2	
48381202	16	2	200	16	-	12	9	4	2	
48381214	18	2,5	200	20	-	14	11	4	2	
48381228	20	2,5	200	20	-	16	12	4	2	

Taroudage | Taraud coupant

Metrique



# M-SFT-DUPLEX NOUVEAU

Taraudage | Taraud coupant | Metrique Fin

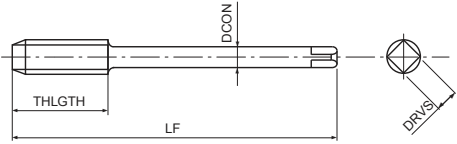

- Taraud coupant hélicoïdal fritté pour trous borgnes
- Revêtement TiN pour une meilleure résistance à la chaleur
- Pour les matériaux difficiles tels que 304L, 316L, 15-5PH & 17-4PH, Super Duplex 1.4410, Inconel 625

Taraudage | Taraud coupant

<b>P</b> ○ C < 0,2%	<b>P</b> ○ 0,25 < C < 0,4	<b>P</b> ○ C ≥ 0,45%	<b>P</b> ○ SCM	<b>M</b> ● INOX	<b>S</b> ● Inconel 625	<b>S</b> ● Ti Gr.2		
				<b>3-15</b> Super Duplex	<b>2-3</b> 15-5 PH	<b>3-6</b> 17-4 PH	<b>m/min</b>	
<b>MF</b>	<b>PM</b>	<b>TiN</b>	<b>50°</b>	<b>ISO 2</b> <b>6HX</b>	<b>C/2,5</b>		<b>DIN 374</b>	

Metrique Fin

EDP	TD	TP	LF	THLGTH	DCON	DRVS	NOF	DIN	Prix
48336156	6	0,75	80	8	4,5	3,4	3	374	
48336157	6	0,5	80	8	4,5	3,4	3	374	
48336162	8	1	90	10	6	4,9	3	374	
48336163	8	0,75	80	10	6	4,9	3	374	
48336170	10	1,25	100	12	7	5,5	4	374	
48336171	10	1	90	12	7	5,5	4	374	
48336180	12	1,5	100	14	9	7	4	374	
48336181	12	1,25	100	14	9	7	4	374	
48336182	12	1	100	14	9	7	4	374	
48336192	14	1,5	100	16	11	9	4	374	
48336203	16	1,5	100	16	12	9	4	374	
48336216	18	1,5	110	20	14	11	4	374	
48336230	20	1,5	125	20	16	12	4	374	
48336240	22	1,5	125	20	18	14,5	4	374	
48336250	24	1,5	140	24	18	14,5	4	374	



# M-SFT-DUPLEX NOUVELLES DIMENSIONS

Taroudage | Taraud coupant | UNC, UN

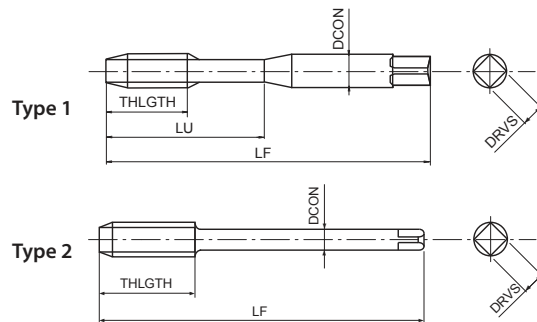

- Taraud coupant hélicoïdal fritté pour trous borgnes
- Revêtement TiN pour une meilleure résistance à la chaleur
- Pour les matériaux difficiles tels que 304L, 316L, 15-5PH & 17-4PH, Super Duplex 1.4410, Inconel 625

Taroudage | Taraud coupant

<b>P</b> ○ C < 0,2%	<b>P</b> ○ 0,25 < C < 0,4	<b>P</b> ○ C ≥ 0,45%	<b>P</b> ○ SCM	<b>M</b> ● INOX	<b>S</b> ● Inconel 625	<b>S</b> ● Ti Gr.2	
				3-15 Super Duplex	2-3 15-5 PH	3-6 17-4 PH	m/min
<b>UNC</b>	<b>PM</b>	<b>TiN</b>	<b>50°</b>	<b>ANSI 2BX</b>	<b>C/2,5</b>	<b>DIN 2184-1</b>	<b>DIN 2184-1</b>

EDP	TD	TP	LF	THLGTH	LU	DCON	DRVS	NOF	Type	DIN	Prix
48336453	2	56	45	3,6	11	2,8	2,1	2	1	DIN2184-1	
48336455	3	48	50	3,6	13	2,8	2,1	2	1	DIN2184-1	
48336457	4	40	56	5,1	18	3,5	2,7	2	1	DIN2184-1	
48336459	5	40	56	5,1	18	3,5	2,7	2	1	DIN2184-1	
48336461	6	32	56	6,4	20	4	3	2	1	DIN2184-1	
48336464	8	32	63	6,4	21	4,5	3,4	2	1	DIN2184-1	
48336466	10	24	70	8,5	25	6	4,9	2	1	DIN2184-1	
48336468	12	24	80	8,5	30	6	4,9	2	1	DIN2184-1	
48336471	1/4	20	80	10,2	30	7	5,5	3	1	DIN2184-1	
48336474	5/16	18	90	11,3	35	8	6,2	3	1	DIN2184-1	
48336479	3/8	16	100	12,7	39	10	8	4	1	DIN2184-1	
48336484	7/16	14	100	14,5	-	8	6,2	4	2	DIN2184-1	
48336489	1/2	13	110	15,6	-	9	7	4	2	DIN2184-1	
48336494	9/16	12	110	16,9	-	11	9	4	2	DIN2184-1	
48336501	5/8	11	110	18,5	-	12	9	4	2	DIN2184-1	
48336515	3/4	10	125	25,4	-	14	11	4	2	DIN2184-1	
48336526	7/8	9	140	28,2	-	18	14,5	4	2	DIN2184-1	
48336538	1	8	160	31,8	-	18	14,5	4	2	DIN2184-1	
48336552	1 1/8	8	180	29	-	22	18	5	2	DIN2184-1	
48336565	1 1/4	8	180	29	-	22	18	5	2	DIN2184-1	
48336578	1 3/8	8	200	33,9	-	28	22	5	2	DIN2184-1	
48336592	1 1/2	8	200	34	-	28	22	5	2	DIN2184-1	
48336605	1 5/8	8	200	33,9	-	32	24	5	2	DIN2184-1	
48336618	1 3/4	8	200	40,6	-	36	29	5	2	DIN2184-1	
48336628	1 7/8	8	225	40,6	-	36	29	5	2	DIN2184-1	
48336639	2	8	225	45,2	-	40	32	5	2	DIN2184-1	



# M-SFT-DUPLEX

Taraudage | Taraud coupant | UNF

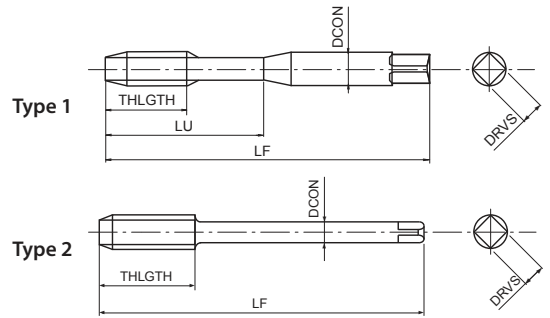

- Taraud coupant hélicoïdal fritté pour trous borgnes
- Revêtement TiN pour une meilleure résistance à la chaleur
- Pour les matériaux difficiles tels que 304L, 316L, 15-5PH & 17-4PH, Super Duplex 1.4410, Inconel 625

<b>P</b> C < 0,2%	<b>P</b> 0,25 < C < 0,4	<b>P</b> C ≥ 0,45%	<b>P</b> SCM	<b>M</b> INOX	<b>S</b> Inconel 625	<b>S</b> Ti Gr.2		
				3-15 Super Duplex	2-3 15-5 PH	3-6 17-4 PH	m/min	
<b>UNF</b>	<b>PM</b>	<b>TiN</b>	<b>50°</b>	<b>ANSI 2BX</b>	<b>C/2,5</b>	<b>DIN 2184-1</b>	<b>DIN 2184-1</b>	

EDP	TD	TP	LF	THLGTH	LU	DCON	DRVS	NOF	Type	DIN	Prix
48336454	2	64	45	3,6	11	2,8	2,1	2	1	DIN2184-1	
48336456	3	56	50	3,6	13	2,8	2,1	2	1	DIN2184-1	
48336458	4	48	56	5,1	18	3,5	2,7	2	1	DIN2184-1	
48336460	5	44	56	5,1	18	3,5	2,7	2	1	DIN2184-1	
48336462	6	40	56	6,4	20	4	3	2	1	DIN2184-1	
48336465	8	36	63	6,4	21	4,5	3,4	2	1	DIN2184-1	
48336467	10	32	70	8,5	25	6	4,9	2	1	DIN2184-1	
48336469	12	28	80	8,5	30	6	4,9	2	1	DIN2184-1	
48336472	1/4	28	80	10,2	30	7	5,5	3	1	DIN2184-1	
48336476	5/16	24	90	11,3	35	8	6,2	3	1	DIN2184-1	
48336481	3/8	24	90	12,7	35	10	8	4	1	DIN2184-1	
48336486	7/16	20	100	14,5	-	8	6,2	4	2	DIN2184-1	
48336491	1/2	20	100	15,6	-	9	7	4	2	DIN2184-1	
48336496	9/16	18	100	16,9	-	11	9	4	2	DIN2184-1	
48336504	5/8	18	100	18,5	-	12	9	4	2	DIN2184-1	
48336517	3/4	16	110	25,4	-	14	11	4	2	DIN2184-1	
48336528	7/8	14	125	28,2	-	18	14,5	4	2	DIN2184-1	
48336539	1	12	140	31,8	-	18	14,5	4	2	DIN2184-1	

Taraudage | Taraud coupant

UNF

# M-SFT-DUPLEX

Taraudage | Taraud coupant | UNJC

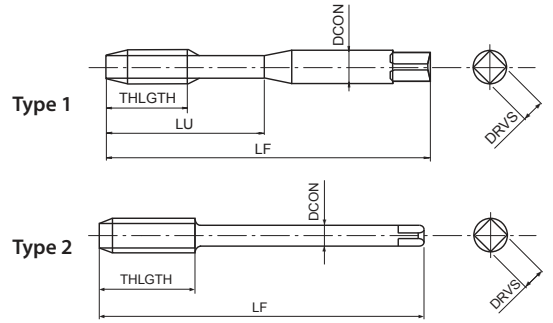

- Taraud coupant hélicoïdal fritté pour trous borgnes
- Revêtement TiN pour une meilleure résistance à la chaleur
- Pour les matériaux difficiles tels que 304L, 316L, 15-5PH & 17-4PH, Super Duplex 1.4410, Inconel 625

Taraudage | Taraud coupant

<b>P</b>	<b>P</b>	<b>P</b>	<b>P</b>	<b>M</b>	<b>S</b>	<b>S</b>						
C < 0,2%	0,25 < C < 0,4	C ≥ 0,45%	SCM	INOX	Inconel 625	Ti Gr.2						
				3-15	2-3	3-6					m/min	
				Super Duplex	15-5 PH	17-4 PH						
UNJC	PM	TiN	50°	ANSI 3BX	C/2,5		DIN 2184-1	DIN 2184-1				

EDP	TD	TP	LF	THLGTH	LU	DCON	DRVS	NOF	Type	DIN	Prix
48373457	4	40	56	5,1	18	3,5	2,7	2	1	DIN2184-1	
48373461	6	32	56	6,4	20	4	3	2	1	DIN2184-1	
48373464	8	32	63	6,4	21	4,5	3,4	2	1	DIN2184-1	
48373466	10	24	70	8,5	25	6	4,9	2	1	DIN2184-1	
48373468	12	24	80	8,5	30	6	4,9	2	1	DIN2184-1	
48373471	1/4	20	80	10,2	30	7	5,5	3	1	DIN2184-1	
48373474	5/16	18	90	11,3	35	8	6,2	3	1	DIN2184-1	
48373479	3/8	16	100	12,7	39	10	8	4	1	DIN2184-1	
48373484	7/16	14	100	14,5	-	8	6,2	4	2	DIN2184-1	
48373489	1/2	13	110	15,6	-	9	7	4	2	DIN2184-1	
48373494	9/16	12	110	16,9	-	11	9	4	2	DIN2184-1	
48373501	5/8	11	110	18,5	-	12	9	4	2	DIN2184-1	
48373515	3/4	10	125	25,4	-	14	11	4	2	DIN2184-1	
48373526	7/8	9	140	28,2	-	18	14,5	4	2	DIN2184-1	
48373538	1	8	160	31,8	-	18	14,5	4	2	DIN2184-1	

# M-SFT-DUPLEX

Taraudage | Taraud coupant | UNJF

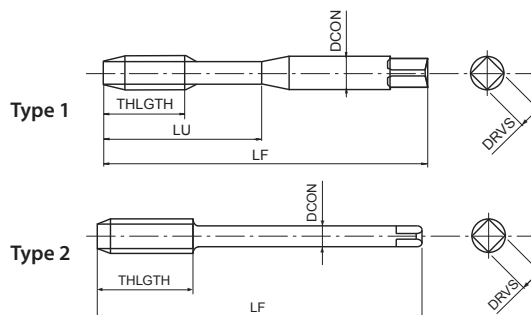

- Taraud coupant hélicoïdal fritté pour trous borgnes
- Revêtement TiN pour une meilleure résistance à la chaleur
- Pour les matériaux difficiles tels que 304L, 316L, 15-5PH & 17-4PH, Super Duplex 1.4410, Inconel 625

<b>P</b> ○ C < 0,2%	<b>P</b> ○ 0,25 < C < 0,4	<b>P</b> ○ C ≥ 0,45%	<b>P</b> ○ SCM	<b>M</b> ● INOX	<b>S</b> ● Inconel 625	<b>S</b> ● Ti Gr.2	
				3-15 Super Duplex	2-3 15-5 PH	3-6 17-4 PH	m/min
<b>UNJF</b>	<b>PM</b>	<b>TiN</b>	<b>50°</b>	<b>ANSI 3BX</b>	<b>C/2,5</b>		<b>DIN 2184-1</b>

EDP	TD	TP	LF	THLGTH	LU	DCON	DRVS	NOF	Type	DIN	Prix
48373458	4	48	56	5,1	18	3,5	2,7	2	1	DIN2184-1	
48373462	6	40	56	6,4	20	4	3	2	1	DIN2184-1	
48373465	8	36	63	6,4	21	4,5	3,4	2	1	DIN2184-1	
48373467	10	32	70	8,5	25	6	4,9	2	1	DIN2184-1	
48373469	12	28	80	8,5	30	6	4,9	2	1	DIN2184-1	
48373472	1/4	28	80	10,2	30	7	5,5	3	1	DIN2184-1	
48373476	5/16	24	90	11,3	35	8	6,2	3	1	DIN2184-1	
48373481	3/8	24	90	12,7	35	10	8	4	1	DIN2184-1	
48373486	7/16	20	100	14,5	-	8	6,2	4	2	DIN2184-1	
48373491	1/2	20	100	15,6	-	9	7	4	2	DIN2184-1	
48373496	9/16	18	100	16,9	-	11	9	4	2	DIN2184-1	
48373504	5/8	18	100	18,5	-	12	9	4	2	DIN2184-1	
48373517	3/4	16	110	25,4	-	14	11	4	2	DIN2184-1	
48373528	7/8	14	125	28,2	-	18	14,5	4	2	DIN2184-1	
48373539	1	12	140	31,8	-	18	14,5	4	2	DIN2184-1	

Taraudage | Taraud coupant



UNJF

# M-SFT-DUPLEX

Taraudage | Taraud coupant | G (BSP)

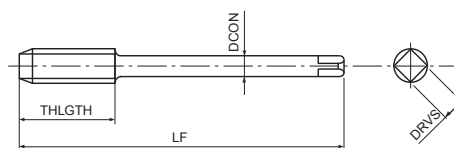

- Taraud coupant hélicoïdal fritté pour trous borgnes
- Revêtement TiN pour une meilleure résistance à la chaleur
- Pour les matériaux difficiles tels que 304L, 316L, 15-5PH & 17-4PH, Super Duplex 1.4410, Inconel 625

Taraudage | Taraud coupant

<b>P</b> ○ C < 0,2%	<b>P</b> ○ 0,25 < C < 0,4	<b>P</b> ○ C ≥ 0,45%	<b>P</b> ○ SCM	<b>M</b> ● INOX	<b>S</b> ● Inconel 625	<b>S</b> ● Ti Gr.2	
				<b>3-15</b> Super Duplex	<b>2-3</b> 15-5 PH	<b>3-6</b> 17-4 PH	<b>m/min</b>
<b>G</b>	<b>PM</b>	<b>TiN</b>	<b>50°</b>	<b>C/2,5</b>	<b>DIN 5156</b>		

EDP	TD	TP	LF	THLGTH	DCON	DRVS	NOF	DIN	Prix
48336900	1/8	28	90	20	7	5,5	4	5156	
48336000	1/4	19	100	22	11	9	4	5156	
48336100	3/8	19	100	22	12	9	4	5156	
48336200	1/2	14	125	25	16	12	4	5156	
48336300	5/8	14	125	25	18	14,5	4	5156	
48336400	3/4	14	140	28	20	16	4	5156	
48336500	7/8	14	150	28	22	18	4	5156	
48336600	1	11	160	30	25	20	4	5156	

# POINTS CLEFS : SYNCHROMASTER

- 1 Permet un contrôle précis de la profondeur Atteint des performances stables même avec un petit chanfrein d'entrée



- 3 Empêche la casse soudaine

- 2 Améliore la qualité du taraudage

- 4 Améliore la durée de vie du taraud

- 5 La combinaison du SynchroMaster et de votre machine avec avance synchronisée fait ressortir le meilleur de vos tarauds

# PORTE TARAUD SYNCHROMASTER

## Le secret réside dans sa conception!

- Le mécanisme de flexion métallique permet une longue durée de vie de l'outil
- Le mécanisme de compensation ultra-petit assure une profondeur de taraudage constante



- Inconvénients des portes taraud à micro compensation classiques
- Le mécanisme de compensation est en 2 parties avec un amortisseur de type résine ou caoutchouc qui se déplace dans le sens de la poussée
  - Dégradation précoce du mécanisme d'amortisseur
  - Nécessite une maintenance

## Longue durée de vie outil

Performance stable même avec un petit chanfrein d'entrée

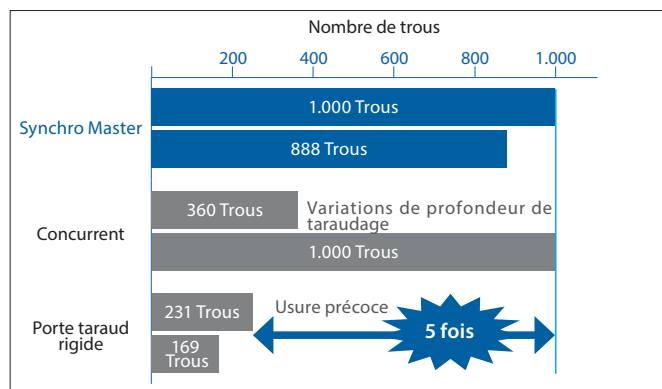

Matière de la pièce: S45C Outil: A-SFT M4x0.7 1P Vitesse de coupe: 10m/min

La durée de vie des tarauds par déformation peuvent aussi être améliorés

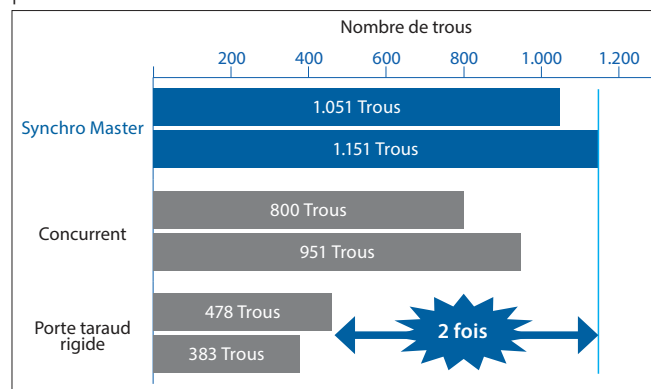

Matière de la pièce: SCM440 (30HRC) Outil: S-XPF M10x1.5 2P Vitesse de coupe: 15m/min

## Supprime les variations de profondeur de taraudage

Permet d'avoir une profondeur de taraudage de haute précision comparable à un porte taraud rigide

Porte Outil	Taraud (exemple)
Synchromaster	0.10 mm
Concurrent	0.20 mm
Porte taraud rigide	0.07 mm

Matière de la pièce: S45C Outil: S-XPF M10x1,5 2P Vitesse de coupe: 22m/min

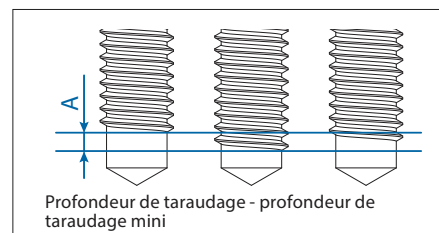

SynchroMaster (Porte outil + Ecrou)



Pince (vendu séparément)



Clef (vendu séparément)

# SYNCHROMASTER NOUVELLES DIMENSIONS

Taroudage | Porte Outil | SynchroMaster



Polygon Taper Shank Holder

- Porte taraud synchronisé
- Améliore la durée de vie outil
- Pour le taroudage de M3 à M24
- Type HSK, BT, CAPTO et ST pour les pinces ER16, type ST et CAPTO pour les pinces ER32

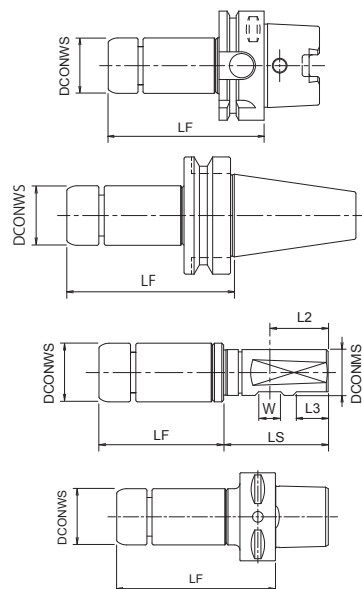

EDP	Designation	LF	LS	DCONWS	DCONMS	L2	L3	Prix
79912	HSK40A-SMH16-85	85	-	32	-	-	-	
79913	HSK63A-SMH16-90	90	-	32	-	-	-	
79910	BT30-SMH16-90	90	-	32	-	-	-	
79911	BT40-SMH16-90	90	-	32	-	-	-	
79924	ST20D-SMH16-68	68	51	32	20	25	-	
79925	ST25D-SMH16-68	68	57	32	25	32	17	
48329004	ST20D-SMH32-87	87	51	50	20	25	-	
48329002	ST25D-SMH32-87	87	57	50	25	32	17	
79994	C4-SMH16-90A	90	-	32	-	-	-	
79995	C5-SMH16-90A	90	-	32	-	-	-	
79996	C6-SMH16-90A	90	-	32	-	-	-	
79997	C5-SMH32-120A	120	-	50	-	-	-	
79998	C6-SMH32-120A	120	-	50	-	-	-	

## Accessoires & pièces détachées

Applicable	EDP	Désignation	Spécification	Prix
SMH16	79923	FKT-32L	Wrench	
SMH16	79922	ERP-16T	Cap Nut	
SMH32	79993	FKT-50L	Wrench	
SMH32	79992	ERP-32T	Cap Nut	

# SYNCHROMASTER PINCE

Taroudage | Porte Outil | SynchroMaster

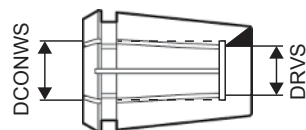

EDP	Désignation	DCONWS	DRVS	DIN 371	DIN 376	Prix
79949	ER16GH3,5,2,7	3,5	2,7	M3	M5	
79951	ER16GH4,5,3,4	4,5	3,4	M4	M6	
79953	ER16GH6,4,9	6	4,9	M5 M6	M8	
79919	ER16GH7,5,5	7	5,5	M7	M10	
79955	ER16GH8,6,3	8	6,3	M8	M11	
79956	ER16GH9,7,1	9	7,1	M9	M12	
79970	ER32GH-7x5,5	7	5,5	M7	M10	
48329007	ER32GH-8x6,3	8	6,3	M8	M11	
48329008	ER32GH-9x7,1	9	7,1	M9	M12	
79973	ER32GH-10x8	10	8	M10	-	
79975	ER32GH-11x9	11	9	-	M14	
79976	ER32GH-12x9	12	9	-	M16	
79978	ER32GH-14x11,2	14	11,2	-	M18	
79980	ER32GH-16x12	16	12	-	M20	
48329014	ER32GH-18x14,5	18	14,5	-	M22 M24	



**OSG EUROPE LOGISTICS**

Avenue Lavoisier 1  
B-1300 Z.I. Wavre - Nord - Belgium  
Tel: +32 10 23 05 07  
info@osgeurope.com

**OSG POLAND Sp. z o.o.**

Spółdzielcza 57  
05-074 Halinów - Poland  
Tel: +22 760 82 71  
osg@osg-poland.com

**OSG ROMANIA SRL**

25C, Bucuresti-Magurele Street (Sector 5)  
051431 Bucuresti - România  
Tel: +40 21 322 07 47  
info@osgromania.ro

**OSG BELUX**

Avenue Lavoisier 1  
B-1300 Z.I. Wavre - Nord - Belgium  
Tel: +32 10 23 05 11  
info@osg-belgium.com

**OSG GERMANY**

Karl-Ehmann-Str. 25  
D - 73037 Göppingen - Germany  
Tel: +49 7161 6064 - 0  
Fax: +49 7161 6064 - 444  
info@osg-germany.de

**AUSTRIA**

Branch office of OSG GERMANY  
Messestraße 11  
A-6850 Dornbirn  
Tel: +49 7161 6064-0  
info@osg-germany.de

**OSG FRANCE**

Parc Icade, Paris Nord 2  
Immeuble "Le Rimbaud"  
22 Avenue des Nations  
CS66191 - 93420 Villepinte - France  
Tel: +33 1 49 90 10 10  
sales@osg-france.com

**OSG SCANDINAVIA**

(For Scandinavian countries)  
Langebjergvaenget 16  
4000 Roskilde - Denmark  
Tel: +45 46 75 65 55  
osg@osg-scandinavia.com

**OSG ITALIA**

Via Ferrero, 65 A/B3  
I - 10098 Rivoli - Italy  
Tel: +39 0117705211  
info@osg-italia.it

**OSG NETHERLANDS**

Bedrijfsweg 5 - 3481 MG Harmelen  
Tel: +31 348 44 2764  
info@osg-nl.com

**SWEDEN**

Branch office of OSG SCANDINAVIA  
Singelgatan 7  
212 28 Malmö - Sweden  
Tel: +46 40 41 22 55  
osg@osg-scandinavia.com

**Vischer & Bolli AG**

Machining and Workholding  
Im Schossacher 17  
CH-8600 Dübendorf  
T +41 44 802 15 15  
info@vb-tools.com

**OSG UK**

Kelsey Close, Attleborough Fields Ind Est,  
CV11 6RS, Nuneaton, United Kingdom.  
Tel: +44 1827 720 013  
uk\_sales@osg-uk.com

**OSG IBERICA**

Bekolarra 4  
E - 01010 Vitoria-Gasteiz - Spain  
Tel: +34 945 242 400  
osg.iberica@osg-ib.com

**CZECH, SLOVAKIA, HUNGARY**

OSG Europe Logistics S.A.  
Slovakia organizacna zlozka  
Racianská 22/A, SK-83102 Bratislava  
Slovakia  
Tel. +421 24 32 91 295  
Orders-osgsvk@osgeurope.com

**OSG TURKEY**

Rami Kışla Cad.No:56 Eyüp  
Istanbul 34056 - Turkey  
Tel+90 212 565 24 00  
Fax: +90 212 565 44 00  
info@osg-turkey.com

**OSG EUROPE LOGISTICS S.A.**

06/2024 - All rights reserved. © OSG Europe 2024.

The contents of this catalogue are provided to you for viewing only. They are not intended for reproduction either in part or in whole in this or other medium. They cannot be copied, used to create derivation work or used for any reason, by means without the express, written permission of the copyright owner. If prices are stated, they are netto unit-prices and any eventual tax(es) have to be added. The company is not responsible for any printing error in technical, price and/or any other data.

Tool specifications subject to change without notice.

[www.osgeurope.com](http://www.osgeurope.com)

